



HIAB eX.302 HI PRO

BASIC DATA
2024.12

HIAB eX.302 HIPRO

BASIC DATA

Technical data	eX.302 HIPRO E-6	eX.302 HIPRO E-6 Jib 45X-3	eX.302 HIPRO E-8	eX.302 HIPRO EP-5
Mdyn (kNm)	325			
Lifting capacity (kNm)	245		236	255
Lifting capacity (tm)	25		24.1	26
Outreach – lifting capacity, standard (m - kg)	2.6 – 9400	19.2 – 540	2.5 – 9200	4.5 – 5800
	4.5 – 5500	20.8 – 480	4.7 – 5100	6.2 – 4050
	6.1 – 3900	22.7 – 430	6.3 – 3550	8.2 – 2940
	7.9 – 2840	24.6 – 390	8.1 – 2540	10.4 – 2240
	9.8 – 2180	–	10 – 1880	12.7 – 1800
	11.8 – 1740	–	12 – 1460	15 – 1520
	13.9 – 1420	–	14.1 – 1160	–
	16.1 – 1220	–	16.3 – 940	–
	–	–	18.6 – 800	–
–	–	20.9 – 700	–	
Outreach – lifting capacity, manual extensions (m – kg)	18.3 – 980	–	22.4 – 600	17.2 – 1260
Hydraulic outreach, standard (m)	16.2	24.7	21	15.1
Hydraulic boom extension (m)	11.7	17.1	16.3	10.6
Outreach, manual extensions (m)	18.4	–	22.6	–
Lifting height above installation level, hydr/man (m)	18.8 / 23.1	27.2 / 0.0	23.6 / 25.1	17.7 / 19.8
Rec. fixed oil flow (l/min)	70 – 90			
Rec. variable oil flow (l/min)	90 – 120			
Working pressure (Mpa)	33.5			
Oil in tank (l)	150 – 200			
Tank capacity (l)	0 – 235			
Slewing angle (°)	420			
Max slope viable at full capacity (°)	5			
Slewing torque, gross (kNm)	34			
Slewing speed (°/s)	15			
Lifting speed at standard hydraulic outreach (m/s)	2.1		2.7	2.2
Height in folded position (mm)	2401	2633	2401	2393
Width in folded position (mm)	2505		2508	2503
Install space required with hose and pipe kit (mm)	1166	1215	1202	1153
Crane in standard version without stabiliser system (kg)	3480	4020	3750	3210
Frame attachments (kg)	56 – 63			
Stabiliser system equipment (kg)	381 – 465			

This table shows a few examples of models, and represents some of all options available. With the opportunity to configure your crane, we can provide you with a crane perfectly tailored to your needs.

Please contact your local dealer for more information on the variety of options we can offer.

HIAB eX.302 HIPRO*

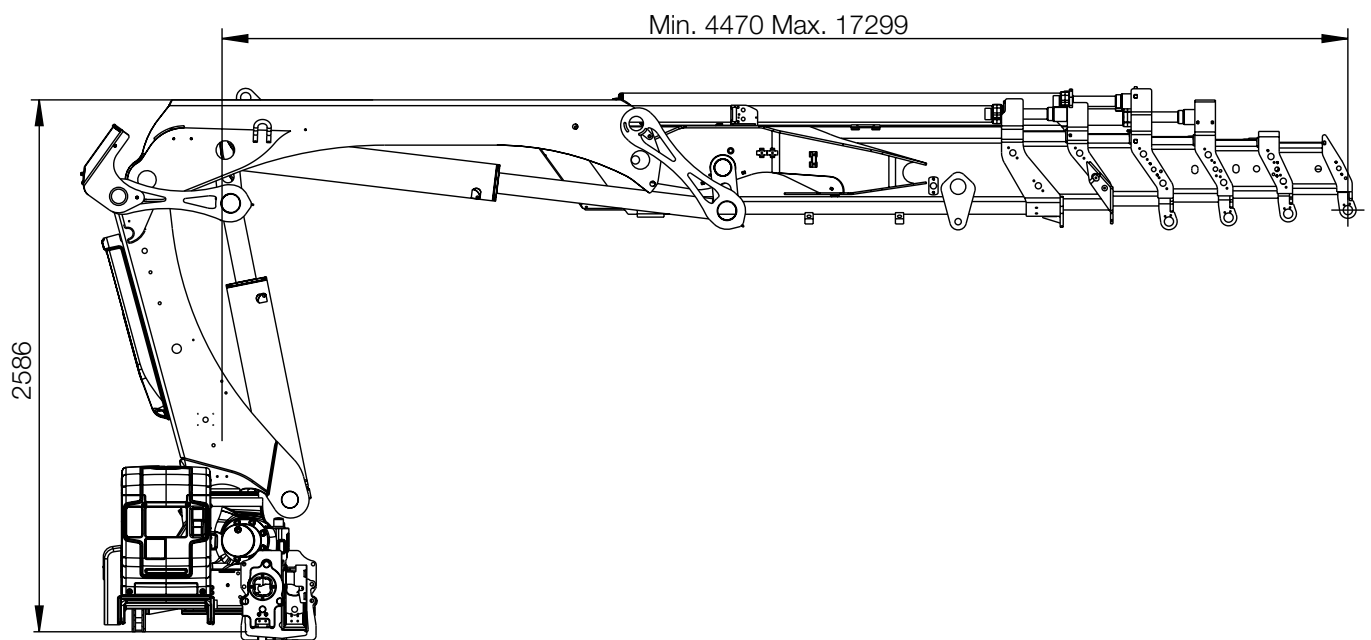
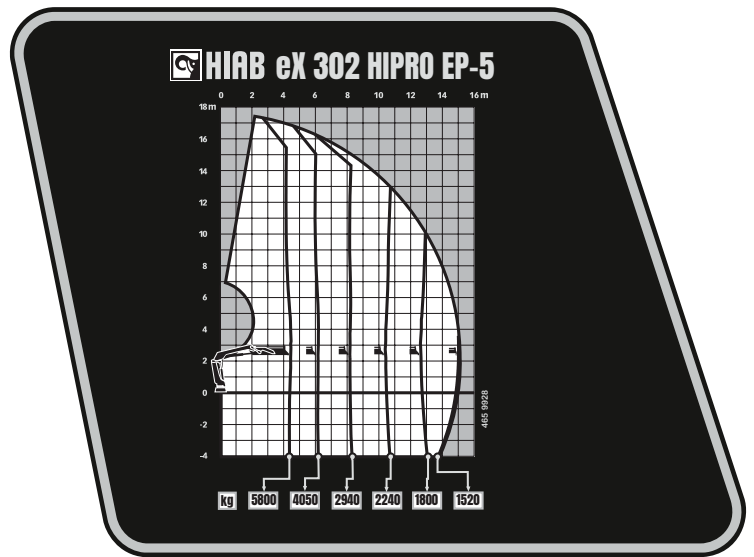
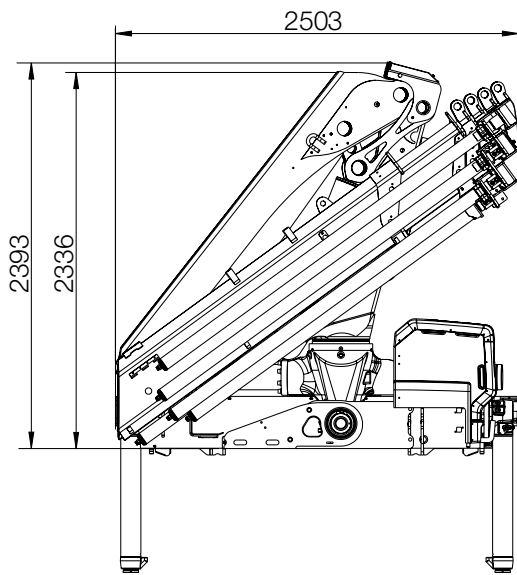

Disclaimer. We reserve the right to make changes. Illustrations, drawings and data are not always in accordance with the latest version or standard model in production. The models in the pictures may present special equipment or colours.

BUILT TO PERFORM

Hiab is a leading provider of smart and sustainable load handling solutions. We are committed to delivering the best customer experience every day with the most engaged people and partners. Hiab's premium equipment includes HIAB, EFFER and ARGOS loader cranes, MOFFETT and PRINCETON truck mounted forklifts, LOGLIFT forestry cranes, JONSERED recycling cranes, MULTILIFT skiploaders and hooklifts, GALFAB roll-off cable hoists, and tail lifts under the ZEPRO, DEL and WALTCO brands. As the industry pioneer, Hiab continues to make load handling smarter, safer and more sustainable to build a better tomorrow. Hiab is part of Cargotec Corporation.

www.hiab.com

