



# **HIAB** 23 CL

BASIC DATA  
2025.01

# HIAB 23 CL

## BASIC DATA

Technical data	23 CL B-2	23 CL B-3	23 CL B-4
Mdyn (kNm)	248	250	252
Lifting capacity (ADC) (kNm)	199.4	195.2	186.9
Lifting capacity (ADC) (tm)	20.3	19.9	19.1
Outreach – lifting capacity, standard (m - kg)	3.3 – 6100	3.5 – 5700	3.7 – 5200
	4.6 – 4400	4.7 – 4150	4.7 – 4050
	6.4 – 3150	6.4 – 3000	6.4 – 2850
	8.4 – 2400	8.4 – 2240	8.4 – 2120
	–	10.4 – 1800	10.5 – 1640
	–	–	12.6 – 1360
Hydraulic outreach, standard (m)	8.7	10.8	12.9
Hydraulic boom extension (m)	3.9	5.8	8
Lifting height above installation level (m)	11.1	13.2	15.3
Rec. fixed oil flow (l/min)	10 – 30		
Working pressure (Mpa)	33		
Oil in tank (l)	64		
Tank capacity (l)	85		
Slewing angle (°)	415		
Max slope viable at full capacity (°)	5		
Slewing torque, gross (kNm)	28.3		
Lifting speed at standard hydraulic outreach (m/s)	0.6	0.7	0.9
Height in folded position (mm)	2267		
Width in folded position (mm)	2476		
Install space required with hose and pipe kit (mm)	846	953	
Crane in standard version without stabiliser system (kg)	1850	2040	2150
Frame attachments (kg)	65		
Stabiliser system equipment (kg)	271 – 319		

*This table shows a few examples of models, and represents some of all options available. With the opportunity to configure your crane, we can provide you with a crane perfectly tailored to your needs.*

*Please contact your local dealer for more information on the variety of options we can offer.*

# HIAB 23 CL\*

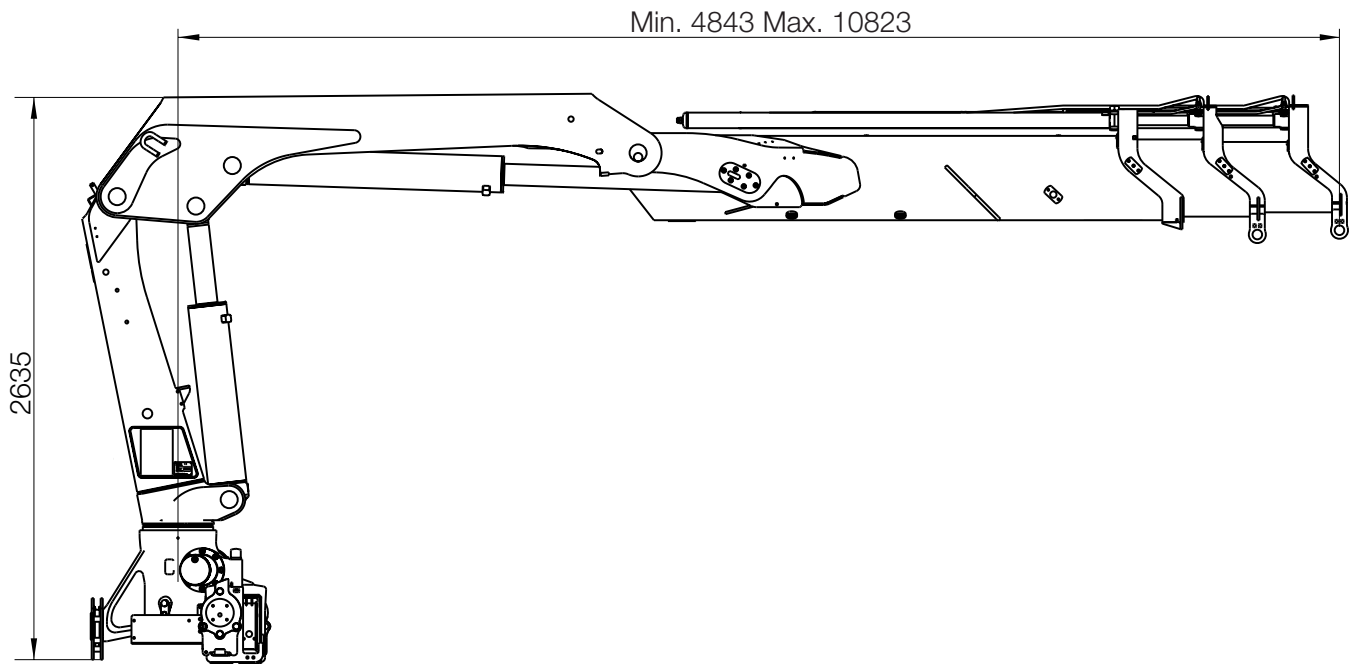
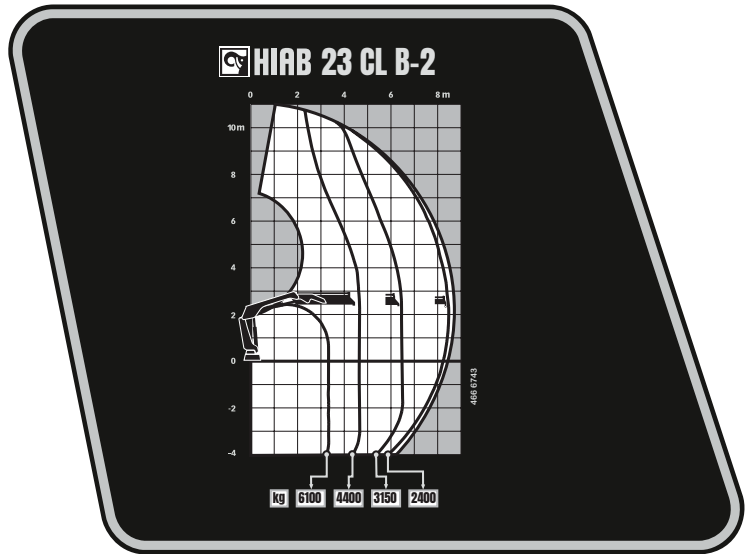
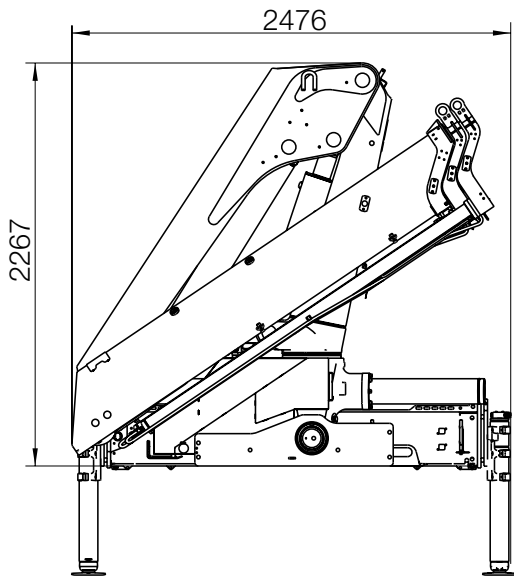

**Disclaimer.** We reserve the right to make changes. Illustrations, drawings and data are not always in accordance with the latest version or standard model in production. The models in the pictures may present special equipment or colours.

# BUILT TO PERFORM

Hiab is a leading provider of smart and sustainable load handling solutions. We are committed to delivering the best customer experience every day with the most engaged people and partners. Hiab's premium equipment includes HIAB, EFFER and ARGOS loader cranes, MOFFETT and PRINCETON truck mounted forklifts, LOGLIFT forestry cranes, JONSERED recycling cranes, MULTILIFT skiploaders and hooklifts, GALFAB roll-off cable hoists, and tail lifts under the ZEPRO, DEL and WALTCO brands. As the industry pioneer, Hiab continues to make load handling smarter, safer and more sustainable to build a better tomorrow. Hiab is part of Cargotec Corporation.

[www.hiab.com](http://www.hiab.com)

