



HIAB 19 CL

BASIC DATA
2025.01

HIAB 19 CL

BASIC DATA

Technical data	19 CL B-2	19 CL B-3	19 CL B-4
Mdyn (kNm)	215	217	218
Lifting capacity (ADC) (kNm)	169.4	164.8	160.6
Lifting capacity (ADC) (tm)	17.3	16.8	16.4
Outreach – lifting capacity, standard (m - kg)	3.2 – 5400	3.4 – 4950	3.4 – 4800
	4.6 – 3750	4.6 – 3600	4.6 – 3500
	6.4 – 2650	6.4 – 2500	6.4 – 2400
	8.4 – 2020	8.4 – 1860	8.4 – 1740
	–	10.4 – 1500	10.4 – 1360
	–	–	12.5 – 1120
Hydraulic outreach, standard (m)	8.6	10.7	12.9
Hydraulic boom extension (m)	3.9	5.9	8.5
Lifting height above installation level (m)	11.1	13.1	15.3
Rec. fixed oil flow (l/min)	10 – 30		
Working pressure (Mpa)	33		
Oil in tank (l)	64		
Tank capacity (l)	85		
Slewing angle (°)	415		
Max slope viable at full capacity (°)	5		
Slewing torque, gross (kNm)	28.3		
Lifting speed at standard hydraulic outreach (m/s)	0.7	0.9	1
Height in folded position (mm)	2265		
Width in folded position (mm)	2485		
Install space required with hose and pipe kit (mm)	865	950	865
Crane in standard version without stabiliser system (kg)	1760	1920	2060
Frame attachments (kg)	65		
Stabiliser system equipment (kg)	271 – 319		

This table shows a few examples of models, and represents some of all options available. With the opportunity to configure your crane, we can provide you with a crane perfectly tailored to your needs.

Please contact your local dealer for more information on the variety of options we can offer.

HIAB 19 CL*

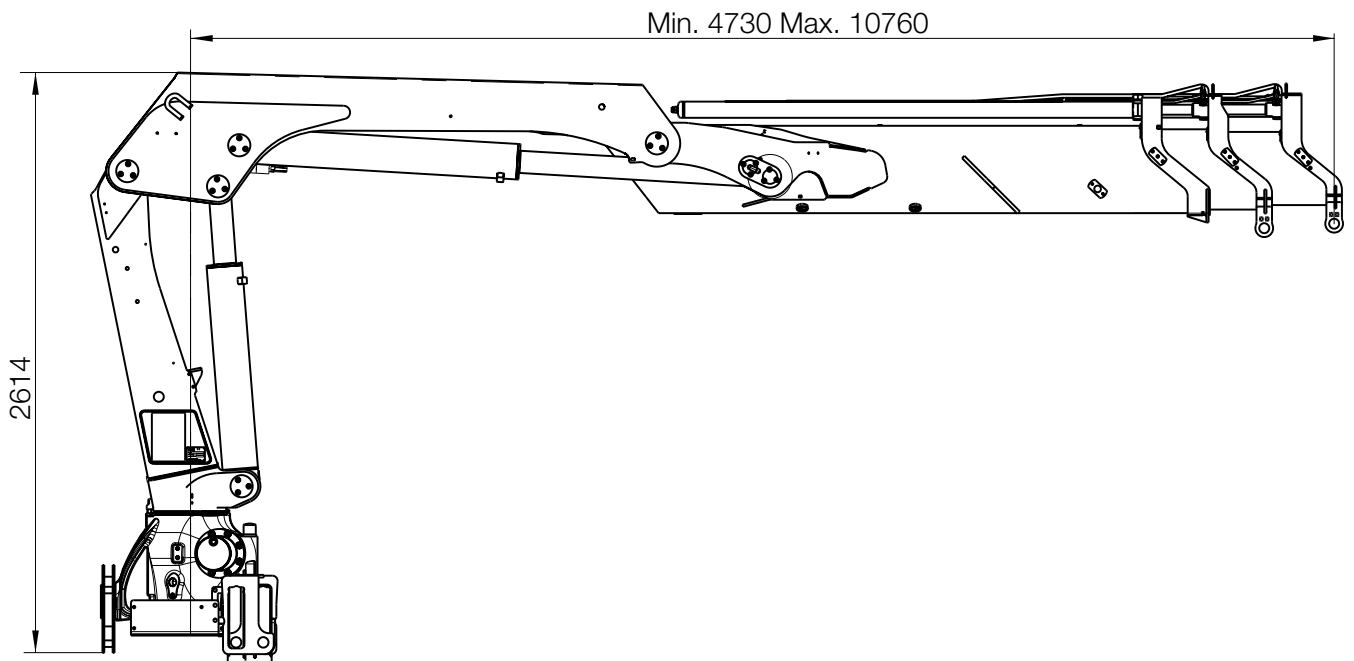
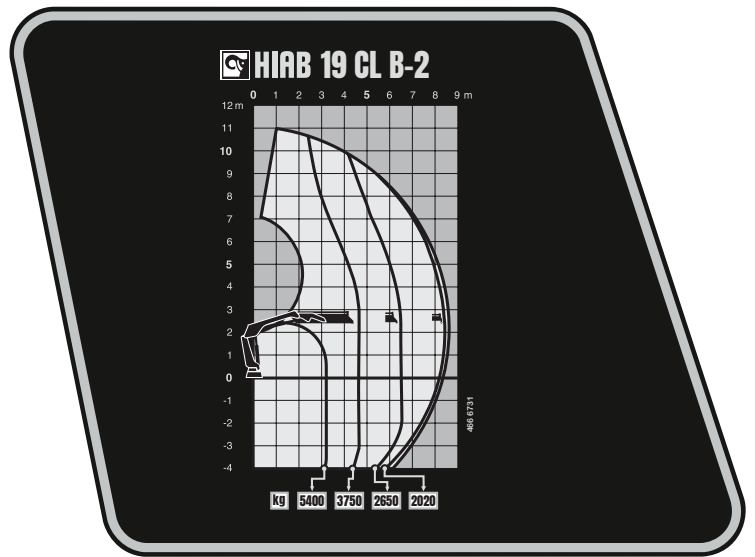
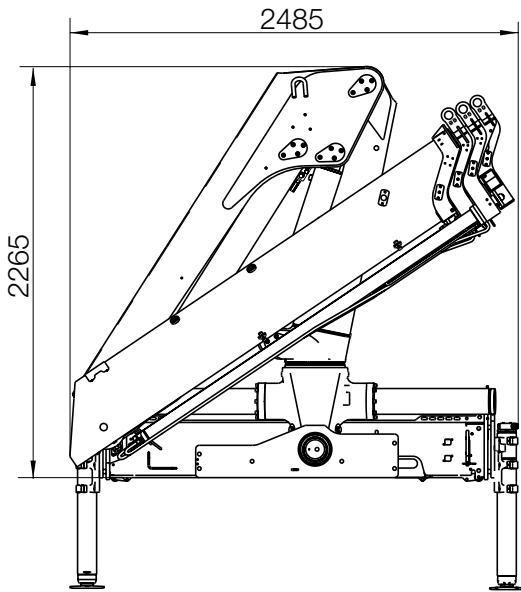

Disclaimer. We reserve the right to make changes. Illustrations, drawings and data are not always in accordance with the latest version or standard model in production. The models in the pictures may present special equipment or colours.

BUILT TO PERFORM

Hiab is a leading provider of smart and sustainable load handling solutions. We are committed to delivering the best customer experience every day with the most engaged people and partners. Hiab's premium equipment includes HIAB, EFFER and ARGOS loader cranes, MOFFETT and PRINCETON truck mounted forklifts, LOGLIFT forestry cranes, JONSERED recycling cranes, MULTILIFT skiploaders and hooklifts, GALFAB roll-off cable hoists, and tail lifts under the ZEPRO, DEL and WALTCO brands. As the industry pioneer, Hiab continues to make load handling smarter, safer and more sustainable to build a better tomorrow. Hiab is part of Cargotec Corporation.

www.hiab.com

