



HIAB eX.162 HI PRO

BASIC DATA
2024.06

HIAB eX.162 HIPRO

BASIC DATA

Technical data	eX.162 HIPRO BS-2	eX.162 HIPRO BSS-2	eX.162 HIPRO B-3	eX.162 HIPRO E-5
Mdyn (kNm)	186	183	186	184
Max. lifting capacity (kNm)	157.5	159.2	153.2	140.1
Lifting capacity (tm)	16.1	16.2	15.6	14.3
Outreach – lifting capacity, standard (m - kg)	3.1 - 5200	3.9 - 4150	3.9 - 4000	3.2 - 4450
	4.5 - 3550	4.4 - 3650	4.8 - 3200	4.9 - 2900
	6.3 - 2500	5.9 - 2700	6.6 - 2280	6.7 - 1980
	8.2 - 1940	7.5 - 2120	8.6 - 1700	8.6 - 1460
	-	-	10.7 - 1360	10.7 - 1120
	-	-	-	12.8 - 900
	-	-	-	15.0 - 760
Outreach – lifting capacity, manual extensions (m - kg)	10.4 - 1460	-	12.8 - 1080	17.3 - 440
Hydraulic outreach, standard (m)	8.5	7.9	11	15.1
Outreach, manual extensions (m)	10.7	-	13.2	17.4
Lifting height above installation level, hydr/man (m)	10.9 / 13.1	10.3	13.4 / 15.6	17.5 / 19.8
Rec. fixed oil flow (l/min)	70			
Rec. variable oil flow (l/min)	90 - 120			
Working pressure (Mpa)	33.3			
Tank capacity (l)	85 / 150			
Slewing angle (°)	415			
Max slope viable at full capacity (°)	5.1			
Slewing torque, gross (kNm)	20.5			
Slewing speed (°/s)	16.7			
Lifting speed at standard hydraulic outreach (m/s)	1.6	1.4	2.0	2.8
Height in folded position (mm)	2264			
Width in folded position (mm)	2452	2476		2490
Install space required with hose and pipe kit (mm)	839		942	931
Crane in standard version without stabiliser system (kg)	1570	1520	1710	2080
Frame attachments (kg)	26			
Stabiliser system equipment (kg)	216 - 383			

This table shows a few examples of models, and represents some of all options available. With the opportunity to configure your crane, we can provide you with a crane perfectly tailored to your needs.

Please contact your local dealer for more information on the variety of options we can offer.

HIAB eX.162 HIPRO B-3*

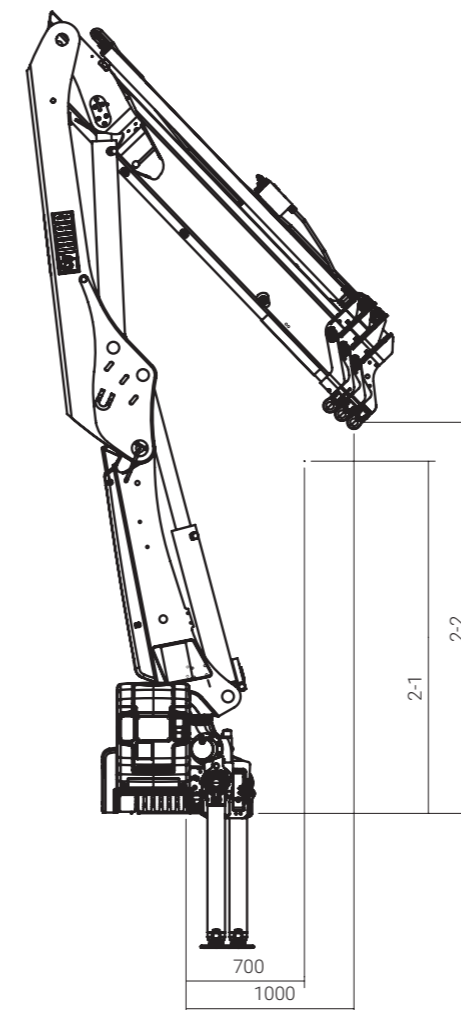
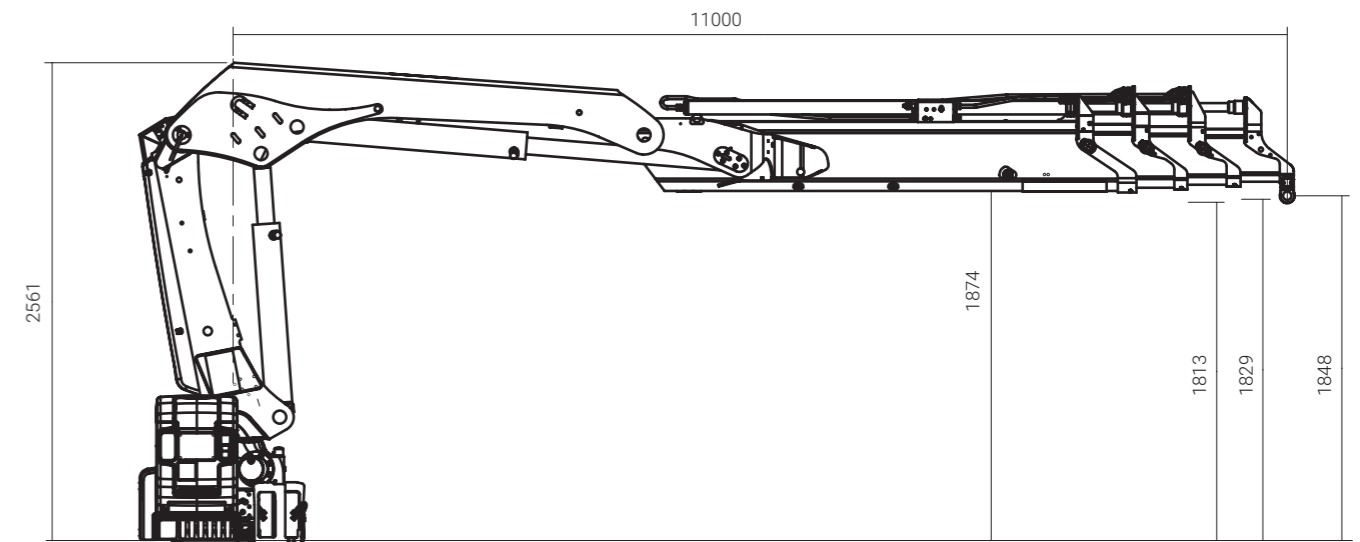

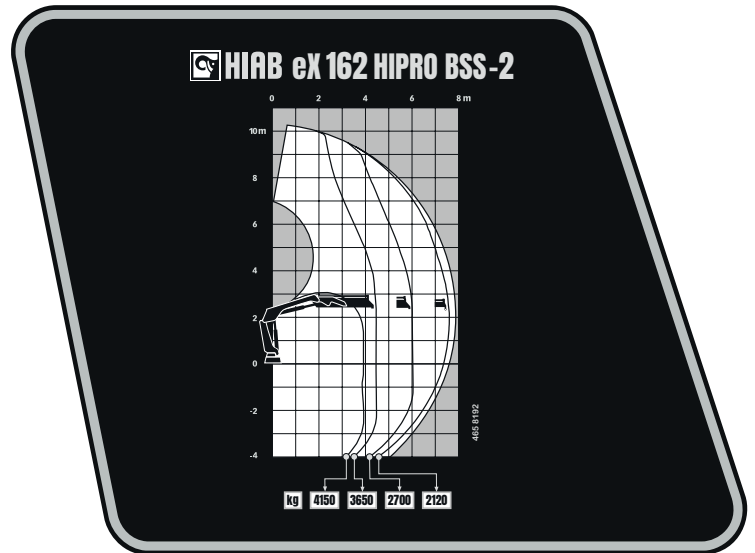
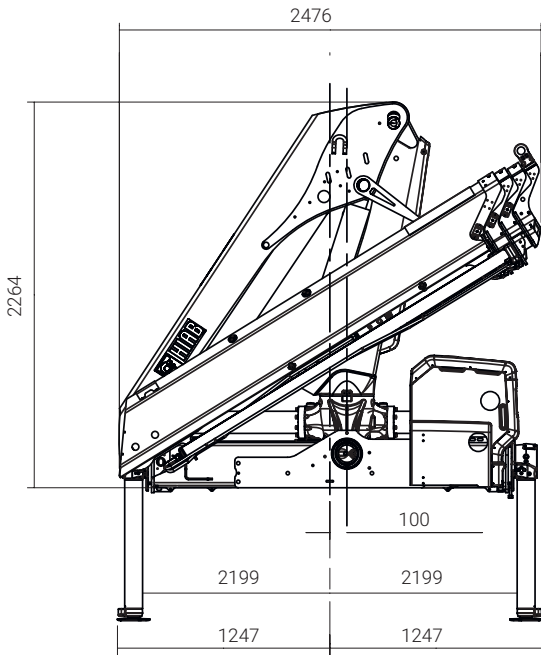

Disclaimer. We reserve the right to make changes. Illustrations, drawings and data are not always in accordance with the latest version or standard model in production. The models in the pictures may present special equipment or colours.

BD-eX.162HIPRO-EN-WW_240703

BUILT TO PERFORM

Hiab is a leading provider of smart and sustainable load handling solutions. We are committed to delivering the best customer experience every day with the most engaged people and partners. Hiab's premium equipment includes HIAB, EFFER and ARGOS loader cranes, MOFFETT and PRINCETON truck mounted forklifts, LOGLIFT forestry cranes, JONSERED recycling cranes, MULTILIFT skiploaders and hooklifts, GALFAB roll-off cable hoists, and tail lifts under the ZEPRO, DEL and WALTCO brands. As the industry pioneer, Hiab continues to make load handling smarter, safer and more sustainable to build a better tomorrow. Hiab is part of Cargotec Corporation.

www.hiab.com

