



HIAB eX.232 HI PRO

BASIC DATA
2024.06

HIAB eX.232 HIPRO

BASIC DATA

Technical data	eX.232 HIPRO E-3	eX.232 HIPRO E-4	eX.232 HIPRO E-5	eX.232 HIPRO E-6
Mdyn (kNm)	249		250	
Lifting capacity (ADC) (kNm)	203	199	194	191
Lifting capacity (ADC) (tm)	20.7	20.2	19.8	19.4
Outreach – lifting capacity, standard (m – kg)	3.5 – 5900	3.5 – 5800	3.6 – 5500	3.6 – 5400
	4.7 – 4400	4.7 – 4300	4.9 – 4050	4.9 – 3950
	6.5 – 3100	6.5 – 3000	6.6 – 2850	6.7 – 2700
	8.5 – 2340	8.5 – 2220	8.6 – 2100	8.6 – 2000
	10.5 – 1880	10.5 – 1760	10.7 – 1620	10.6 – 1520
	–	12.6 – 1460	12.8 – 1320	12.7 – 1220
	–	–	15.0 – 1120	14.9 – 1020
Outreach – lifting capacity, manual extensions (m – kg)	–	–	–	17.2 – 870
Outreach – lifting capacity, manual extensions (m – kg)	12.7 – 1500	14.9 – 1160	17.4 – 560	19.0 – 420
Hydraulic outreach, standard (m)	10.6	12.8	15.1	17.3
Hydraulic boom extension (m)	5.9	8.0	10.2	12.4
Outreach, manual extensions (m)	12.8	15.0	17.5	19.1
Lifting height above installation level, hydr/man (m)	13.1 / 15.3	15.2 / 17.5	17.6 / 19.9	19.8 / 21.6
Rec. fixed oil flow (l/min)	70 – 90			
Rec. variable oil flow (l/min)	90 – 120			
Working pressure (Mpa)	34.5			
Tank capacity (l)	85 / 150			
Slewing angle (°)	415			
Max slope viable at full capacity (°)	5			
Slewing torque, gross (kNm)	28.3			
Slewing speed (°/s)	16			
Lifting speed at standard hydraulic outreach (m/s)	1.8	2.1	2.5	2.9
Height in folded position (mm)	2269			
Width in folded position (mm)	2485		2496	
Install space required with hose and pipe kit (mm)	875		985	985
Crane in standard version without stabiliser system (kg)	2185	2325	2445	2575
Frame attachments (kg)	40 – 65			
Stabiliser system equipment (kg)	271 – 428			

This table shows a few examples of models, and represents some of all options available. With the opportunity to configure your crane, we can provide you with a crane perfectly tailored to your needs.

Please contact your local dealer for more information on the variety of options we can offer.

HIAB eX.232 HIPRO E-5

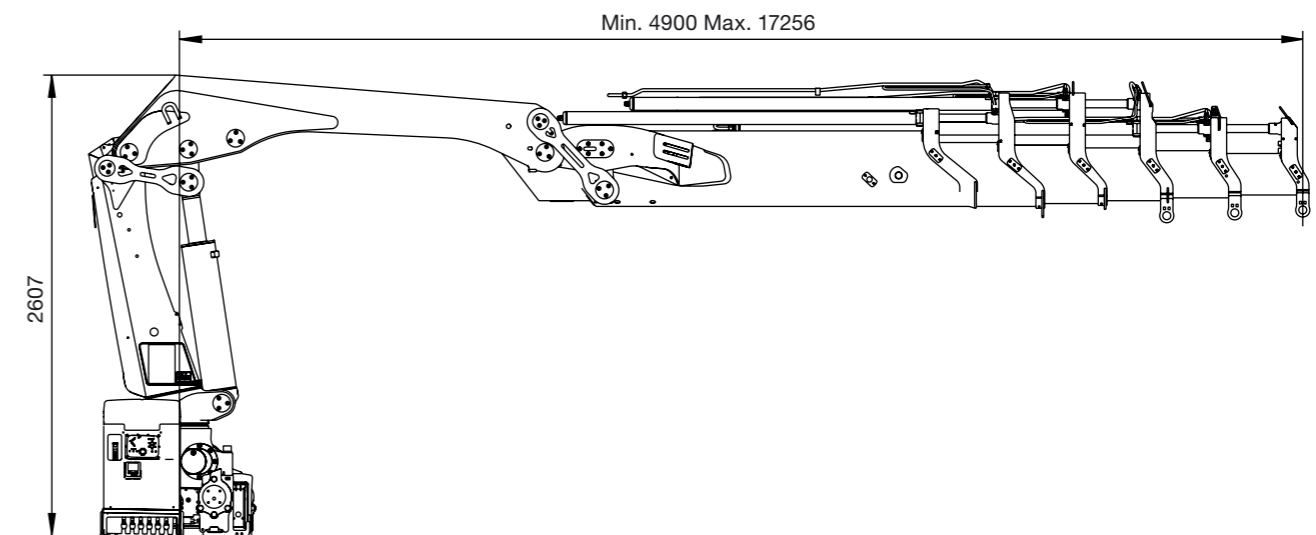
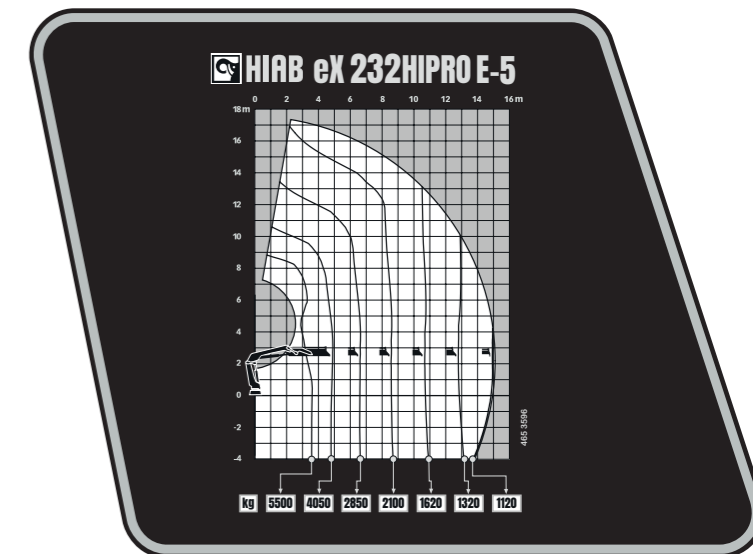
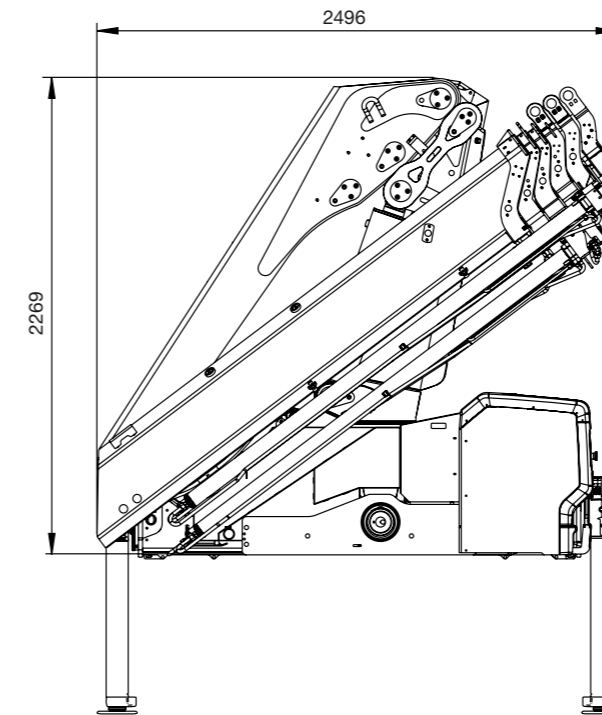

Disclaimer. We reserve the right to make changes. Illustrations, drawings and data are not always in accordance with the latest version or standard model in production. The models in the pictures may present special equipment or colours.

BUILT TO PERFORM

Hiab is a leading provider of smart and sustainable load handling solutions. We are committed to delivering the best customer experience every day with the most engaged people and partners. Hiab's premium equipment includes HIAB, EFFER and ARGOS loader cranes, MOFFETT and PRINCETON truck mounted forklifts, LOGLIFT forestry cranes, JONSERED recycling cranes, MULTILIFT skiploaders and hooklifts, GALFAB roll-off cable hoists, and tail lifts under the ZEPRO, DEL and WALTCO brands. As the industry pioneer, Hiab continues to make load handling smarter, safer and more sustainable to build a better tomorrow. Hiab is part of Cargotec Corporation.

www.hiab.com

