



HIAB ix.188 HIDUO

BASIC DATA
2024.06

HIAB iX.188 HIDUO

BASIC DATA

Technical data	iX.188 HIDUO B-4	iX.188 HIDUO BS-2	iX.188 HIDUO E-5	iX.188 HIDUO E-6
Mdyn (kNm)	210	207	215	216
Lifting capacity (ADC) (kNm)	160	169	155	151
Lifting capacity (ADC) (tm)	16.3	17.3	15.8	15.4
Outreach – lifting capacity, standard (m – kg)	3.4 – 4800	3.4 – 5100	3.2 – 4900	3.3 – 4650
	4.6 – 3500	4.3 – 4000	4.9 – 3200	5.0 – 3050
	6.4 – 2380	6.1 – 2800	6.7 – 2180	6.8 – 2040
	8.4 – 1740	8.1 – 2100	8.7 – 1560	8.8 – 1440
	10.4 – 1360	–	10.7 – 1200	10.8 – 1080
	12.5 – 1120	–	12.8 – 970	12.9 – 850
	–	–	15.0 – 810	15.1 – 700
Outreach – lifting capacity, manual extensions (m – kg)	–	–	–	17.4 – 590
Outreach – lifting capacity, manual extensions (m – kg)	14.8 – 880	10.2 – 1580	17.4 – 450	19.2 – 280
Hydraulic outreach, standard (m)	12.9	8.3	15.2	17.5
Hydraulic boom extension (m)	8.1	3.9	10.3	12.6
Outreach, manual extensions (m)	15.2	10.5	17.5	19.3
Lifting height above installation level, hydr/man (m)	15.3 / 17.6	10.8 / 12.9	17.6 / 20.0	20.0 / 21.9
Rec. fixed oil flow (l/min)	55 – 65			
Rec. variable oil flow (l/min)	55 – 65			
Working pressure (Mpa)	32.9			
Oil in tank (l)	85 / 150			
Slewing angle (°)	190 – 415			
Max slope viable at full capacity (°)	6			
Slewing torque, gross (kNm)	28.3			
Slewing speed (°/s)	15			
Lifting speed at standard hydraulic outreach (m/s)	2.2	1.4	2.6	3.0
Height in folded position (mm)	2265		2260	2265
Width in folded position (mm)	2492	2485	2496	
Install space required with hose and pipe kit (mm)	965	965	985	985
Crane in standard version without support legs (kg)	2135	1825	2395	2515
Frame attachments (kg)	40 – 65			
Stabiliser system equipment (kg)	271 – 428			

This table shows a few examples of models, and represents some of all options available. With the opportunity to configure your crane, we can provide you with a crane perfectly tailored to your needs.

Please contact your local dealer for more information on the variety of options we can offer.

HIAB iX.188 HIDUO B-4

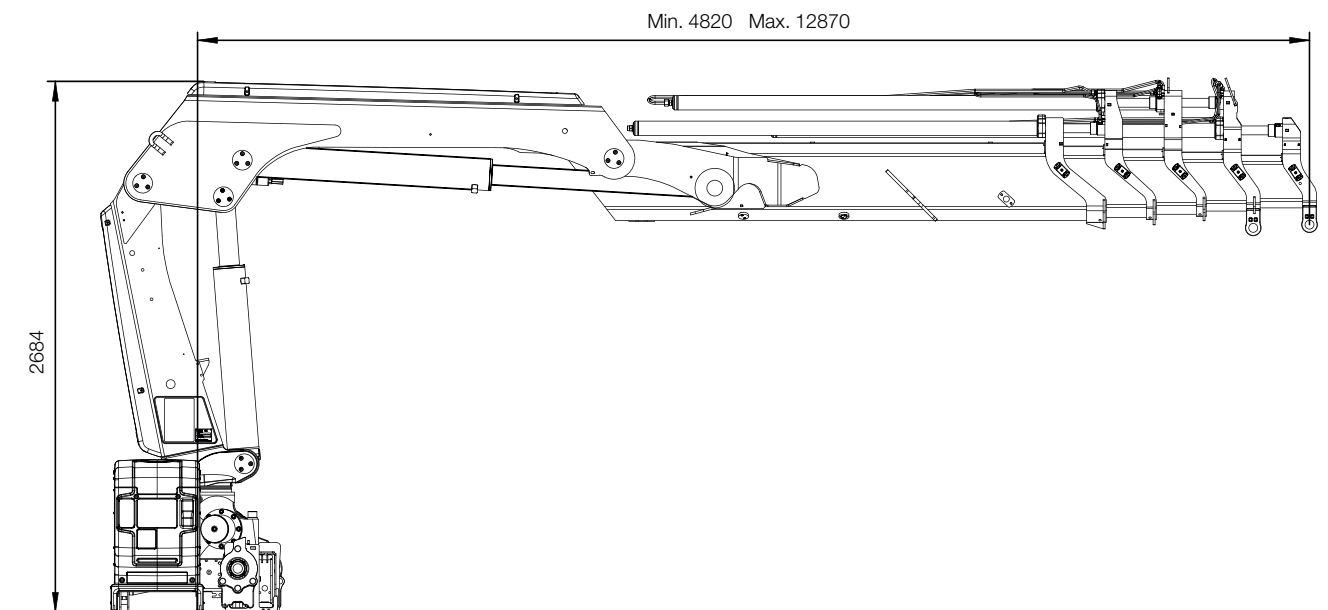
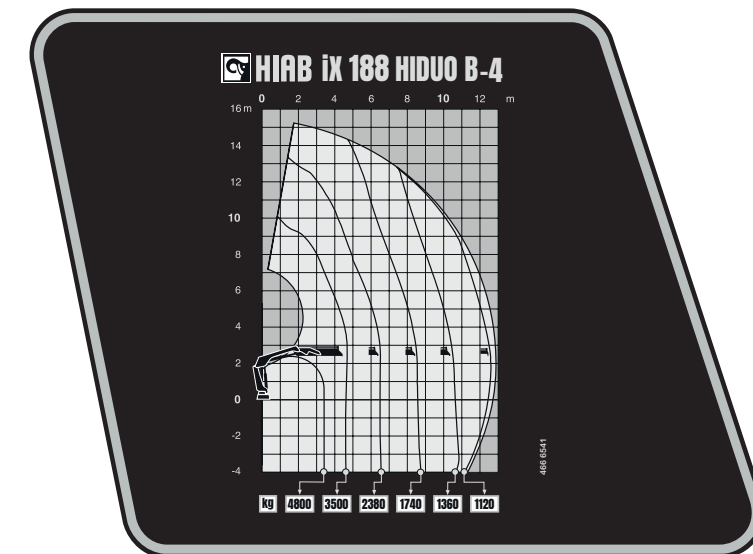
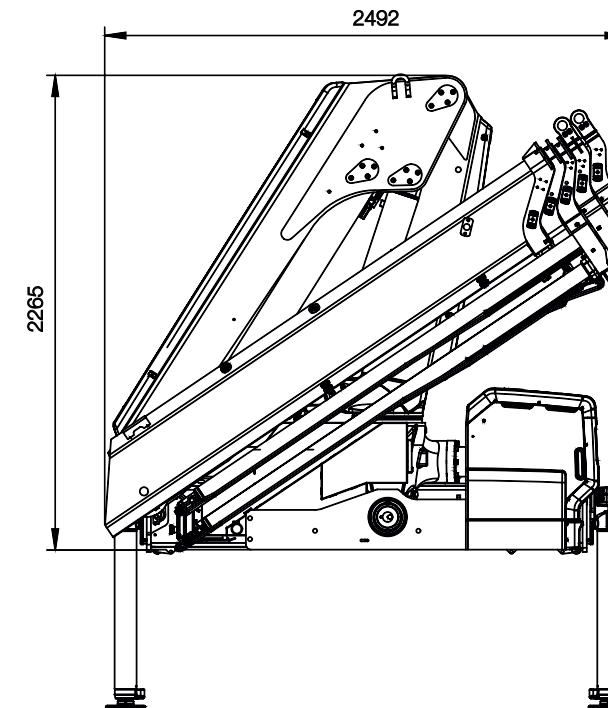

Disclaimer. We reserve the right to make changes. Illustrations, drawings and data are not always in accordance with the latest version or standard model in production. The models in the pictures may present special equipment or colours.

BUILT TO PERFORM

Hiab is a leading provider of smart and sustainable load handling solutions. We are committed to delivering the best customer experience every day with the most engaged people and partners. Hiab's premium equipment includes HIAB, EFFER and ARGOS loader cranes, MOFFETT and PRINCETON truck mounted forklifts, LOGLIFT forestry cranes, JONSERED recycling cranes, MULTILIFT skiploaders and hooklifts, GALFAB roll-off cable hoists, and tail lifts under the ZEPRO, DEL and WALTCO brands. As the industry pioneer, Hiab continues to make load handling smarter, safer and more sustainable to build a better tomorrow. Hiab is part of Cargotec Corporation.

www.hiab.com

