



INTRODUCING MOFFETT M5 NX MORE THAN JUST TOP PERFORMANCE

NX
SERIES



MEET THE NEW-GENERATION MOFFETT M5 NX



Always compliant with MOFFETT

All MOFFETT truck mounted forklifts are Stage V compliant. The Stage V engines powering the forklifts are equipped with a diesel particulate filter (DPF) which catches the particulate matter or soot in the exhaust. With MOFFETT your operation is secure today and tomorrow.

▼ The products shown here in this brochure are part of Hiab's global product selection. Deviations of the selection due to geographical location may occur. Please contact your local Hiab dealer for further details on available models, accessories and options.



Experience the enhanced performance of the new-generation MOFFETT M5 NX. Packed with improvements – on the inside as well as the outside – get ready to do more, experience more and achieve more than ever.

- Upgraded performance
- Easier maintenance
- Enhanced styling
- Improved safety and comfort
- Wide range of options and accessories

The MOFFETT M5 NX is the specialist for medium to heavy-duty tasks, with a seriously efficient power-to-weight ratio. Lifting up to 2,500 kg, the M5 NX easily masters both rough terrain and the most confined areas – transferring loads quickly and safely throughout busy yards, warehouse facilities or traffic.

Gain full support to take you further

MOFFETT truck mounted forklifts are built like no other. And we help you keep that top performance delivering always to your expectations with service like no other. With Original Parts, flexible service contracts and worldwide network of experts, we support you whenever, wherever and however you need us.



▼ Discover more
moffett.hiab.com

NEW FEATURES FOR BETTER PERFORMANCE SAFETY AND COMFORT

MaxPerformance™

Light, but far from
lightweight

Europe's most trusted truck mounted forklift now has even more versatile performance. With the most efficient power-to-weight ratio in the industry.



Mast

High Visibility mast for precise load positioning with numerous options to suit your application



Operator Station

Increased room for operator

Redesigned chassis

Optimised weight distribution

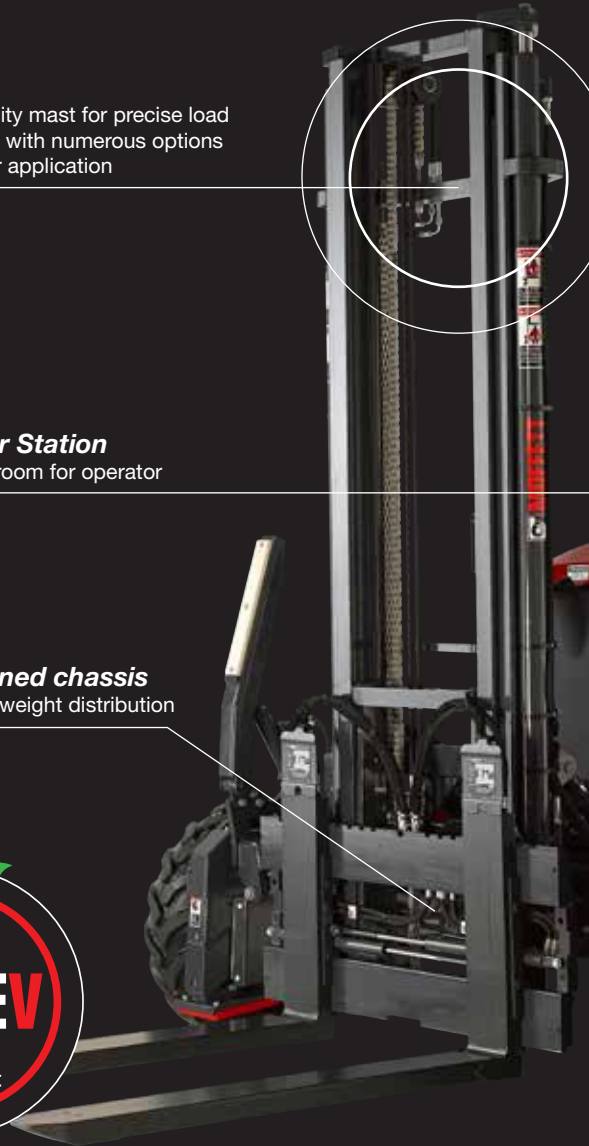

EasyService™

Reduced maintenance time

The MOFFETT M5 NX has a redesigned bonnet and rear doors, access to do daily checks and routine maintenance is made even easier.



PERFORMANCE,

Interlocking seatbelt

Prevents driving if not connected

LED work lights

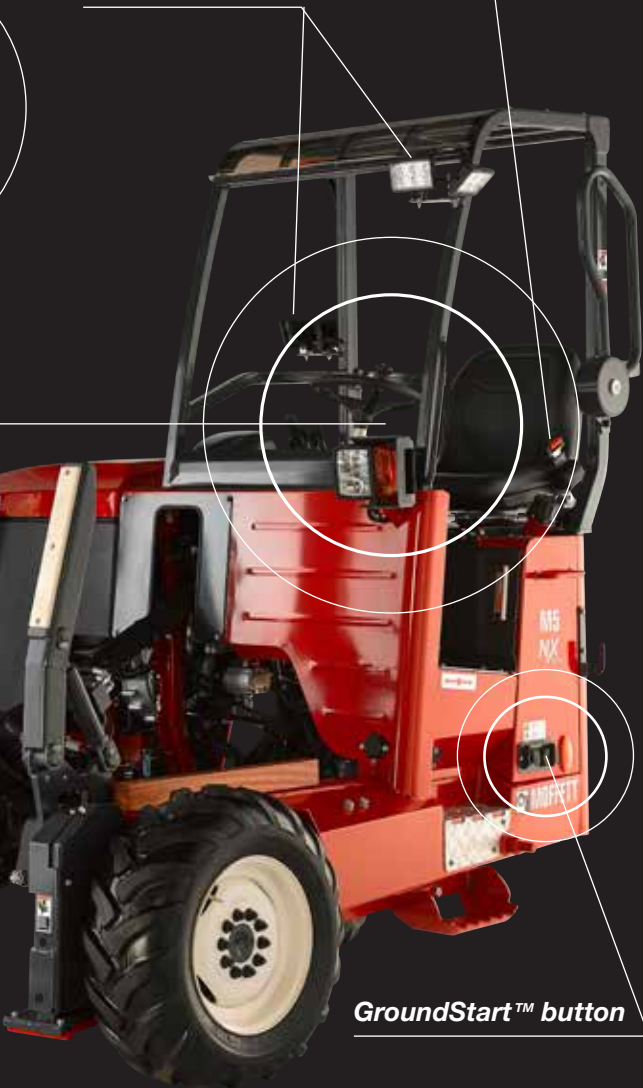

GroundStart™ button

Lift Assist™

True one-side unloading

With our Lift Assist system and the extra reach, you can work with one-side unloading – no matter how confined the workspace. Simply put, you gain more efficiency in tight situations.



SafetyPlus™

Because safety comes first

With the bonnet redesigned for better visibility, LED lights/beacon and Interlocking seat belt, you gain enhanced safety for the operator.



GroundStart™

Enhancing safety

With GroundStart as standard, dismantling the M5 NX is now even easier for the operator no matter the location.



THE MOFFETT M5 NX MAKES BETTER BUSINESS SENSE

Model	M5 NX 20.3	M5 NX 20.4	M5 NX 25.3	M5 NX 25.4
Lift capacity	2,000 kg @ 600 mm	2,000 kg @ 600 mm	2,500 kg @ 600 mm	2,500 kg @ 600 mm
Engine	Kolher KDI1903	Kolher KDI1903	Kolher KDI1903	Kolher KDI1903
Lift height*	3,000 mm	3,000 mm	3,000 mm	3,000 mm
Standard tyres*	280x60-15.5	280x60-15.5	280x60-15.5	280x60-15.5
Overhang**	1,200 mm	1,200 mm	1,200 mm	1,200 mm
Ground clearance	220 mm	220 mm	220 mm	220 mm

Specifications shown here can be changed by the manufacturer without prior notice.

* Other options available

** Values vary depending on machine specification and type of mounting kit

The M5 NX is the specialist for efficient load handling in busy urban traffic and confined operating conditions.

- Window and door delivery
- Recycling and waste management
- Chemicals
- Industrial gas

- Building supply
- Animal feeds
- Beverage products
- Turf
- ...and much more



Options

The M5 NX is lightweight and compact enough to be carried on almost any truck or trailer, and is available with a wide range of options and attachments.



- Remote Ground Mount
- Multi-directional / 4-way system
- Different lift heights



- Various tyre options
- Choice of forks
- Load backrest and many more



DELIVER AS PROMISED WITH HIAB SERVICES

When you invest in Hiab equipment, you invest in quality performance to safely and efficiently fulfill your commitments to your customers – every single day.

With Hiab Services, we are here for you throughout your equipment lifecycle, giving the uptime and reliability you need to deliver as promised. From the moment of installation, we can ensure that your Hiab equipment keeps its original performance – delivering always to your expectations.

With the latest tools, connectivity and a wide network of experts, we support you whenever and wherever you need us. So you can sleep well at night – every single night.



Original Parts

Hiab Original Parts ensure that your Hiab product stays a Hiab product. Keep the same functionality and quality you invested in from the start – essential for optimal performance, maximum safety and avoiding costly downtime.

Hiab ProCare™

Hiab ProCare™ is a flexible service contract designed to secure the uptime of all Hiab equipment. Scheduled and preventive maintenance helps your equipment retain the same high quality you invested in. Using original spare parts and the highest standards, our global service network takes professional care of every piece of your equipment reducing the risk of costly breakdowns and unexpected downtime. Let us take care of all scheduling, maintenance and inspections. By reducing total cost of ownership and increasing the re-sell value of your machine, ProCare brings you total peace of mind. Keep moving to produce as planned and boost your profit.

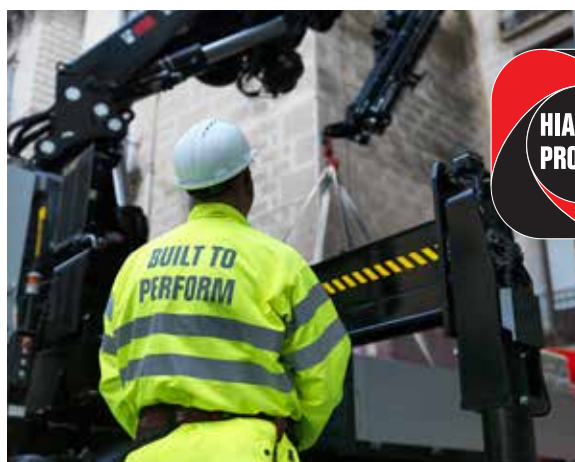

BUILT TO PERFORM

Hiab is the world's leading provider of on-road load handling equipment, intelligent services, smart and connected solutions. Hiab's class-leading load handling equipment includes HIAB, EFFER and ARGOS loader cranes, LOGLIFT and JONSERED forestry and recycling cranes, MOFFETT and PRINCETON truck mounted forklifts, MULTILIFT skiploaders and hooklifts, and tail lifts under the ZEPRO, DEL, and WALTCO brands. As the industry pioneer and with a proud 75 year history, Hiab is committed to be the preferred partner and solution provider to its customers and shape the future of intelligent load handling.

hiab.com

Hiab is part of Cargotec Corporation.

cargotec.com



PB-M5NX-EN-EU_200319

To learn more about MOFFETT
visit moffett.hiab.com

moffettm5.hiab.com



hiab.com